

Overview

The Edgewater EHS-PMC6602 high-performance Network Interface Card (NIC) is designed to provide rapid and affordable data capacity increases on STANAG 3838 and MIL-STD-1553B (3838/1553B) data buses. The additional capacity operates in parallel with and independently of the existing low-speed 3838/1553B signaling. The EHS-PMC6602 complies with NATO STANAG 7221.

The EHS-PMC6602 can add up to 100Mbps of additional capacity as a separate, independent data network operating on the existing data bus infrastructure.

The EHS-PMC6602 NIC is configured as a Remote Terminal (RT) and does not rely on the existing legacy 3838/1553B bus controller to manage the data traffic. No changes are required to the existing 3838/1553B hardware or software infrastructure which leads to a dramatic reduction in the cost to integrate, certify and deploy advanced capabilities requiring increased data capacity.



Figure 1: EHS-PMC6602 PCI Mezzanine Card

Applications

- Transportation of high-speed data such as video, imagery, enhanced vision systems and advanced data communications
- Load reduction on existing 3838/1553B data buses
- Integration into Mission Computers, Stores Management Systems and displays to prepare existing network infrastructure for future development
- Suitable for ground, airborne, surface, and sub-surface platforms integrated with 3838/1553B data buses
- Appropriate for performing cybersecurity upgrades

Features

- High-performance STANAG 7221 compliant interface
- PCI host interface
- Operates on 3838/1553B and MACAIR compatible data buses
- Proven on Green Hills® Integrity
- STANAG 7221 RT Configuration

Driver Support

- VxWorks® 5.5.1, 6.3 and 6.9
- CentOS 7.3
- Microsoft Windows® 7, 8.1 and 10 (4Q2017)

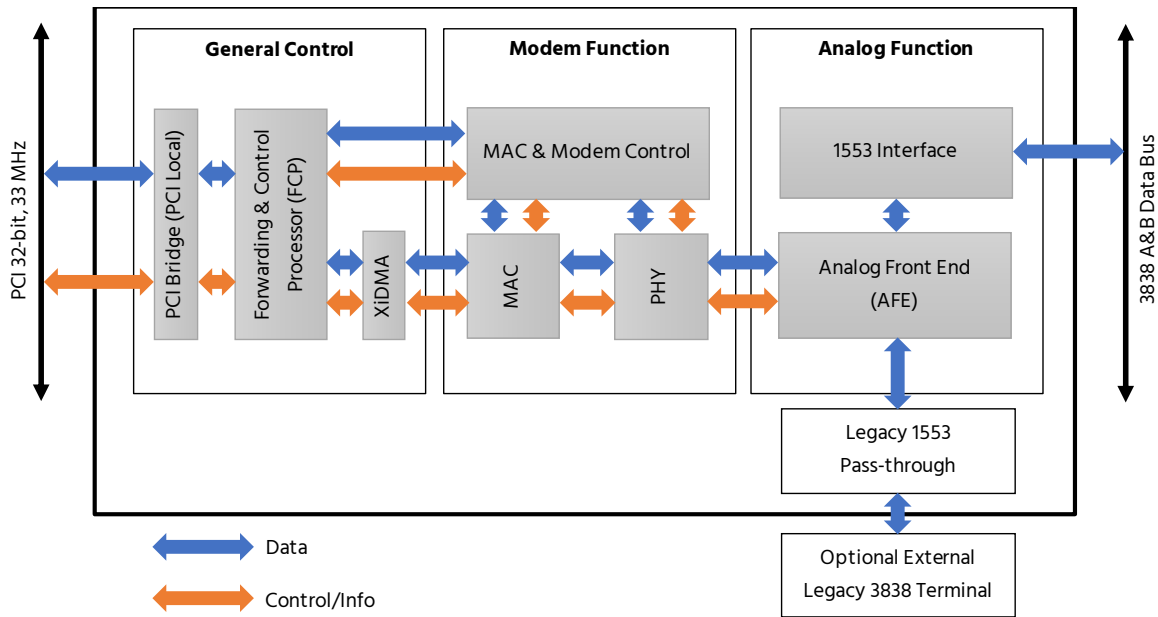

Figure 2: EHS-PMC6602 System Block Diagram

System Interfaces

Mechanical Interface

The EHS-PMC6602 Circuit Card Assembly (CCA) is a single height Peripheral Component Interface (PCI) Mezzanine Card (PMC) which is IEEE P1386.1 form factor compliant and is conduction cooled in accordance with ANSI/VITA 20-2001 (R2011). It can be plugged into any industry compliant conduction cooled carrier card which provides a PCI local bus slot that is keyed for 3.3V bus Input/Output (I/O) voltage. The assembly is cooled through the primary thermal interface and requires no external airflow for temperature regulation.

It is not compatible with carrier cards that have a fixed secondary thermal interface or are keyed for 5V bus I/O voltage.

Complete mechanical interface details are contained in Edgewater document 9001074 EHS-PMC5602 Hardware Reference Manual.

Thermal Interface

Heat is transferred from the EHS-PMC6602 CCA to the host card via contact with two primary thermal interfaces. Note that the secondary thermal interfaces are optional according to ANSI/VITA 20-2001 (R2011) and not used by the CCA. The terminal is designed to meet its thermal specifications through conduction cooling via the primary thermal interfaces. The EHS-PMC6602 can also operate in typical lab environments using convection cooling.

The thermal interfaces are plated with Electroless Nickel Immersion Gold (ENIG) to provide excellent surface co-planarity and maintain thermal performance over time by limiting oxidization and corrosion.

Electrical Interface

All external connections for the EHS-PMC6602 terminal are through the PMC interface. Host communication is through the PCI bus on the PMC

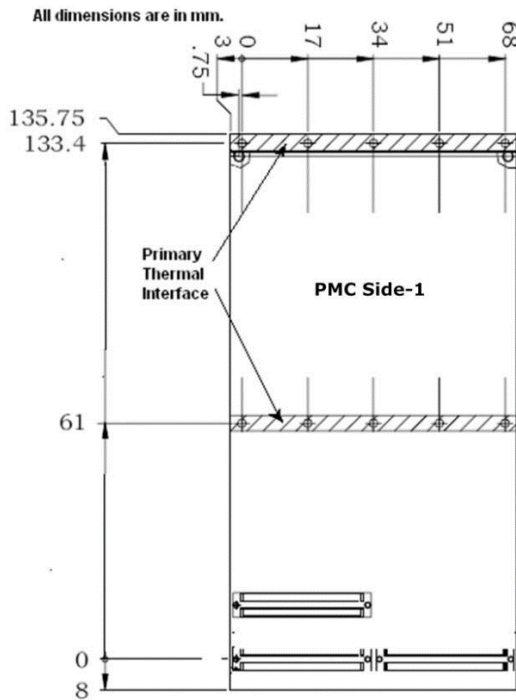

Figure 3: CCA Physical Dimensions

interface and the remaining connections are through the PMC user I/O P14 connector.

Legacy 3838/1553B can optionally be passed through the EHS-PMC6602 terminal to connect to the 3838 bus on the same stub as the STANAG 7221 interface. This allows a legacy 3838/1553B connected LRU to continue using the legacy interface without changes to the legacy interface software and also without wiring changes external to the LRU.

These are further described in the External Interfaces section.

Software Interface

Applications communicate with the terminal using an Application Program Interface (API) through the host driver on the host computer. The API provides a hardware abstraction layer to simplify and reduce the effort required to integrate an EHS-PMC6602 terminal into a system. Refer to Edgewater document 9001041 EHS-PMC5602 API Reference Guide for complete details on the interface.

Host Driver

The host driver interfaces with the user application primarily through the use of Virtual Circuits which are accessed by a Virtual Circuit Endpoint.

Host driver Board Support Package (BSP) have been ported for the following versions of VxWorks:

- VxWorks 5.5.1
- VxWorks 6.3
- VxWorks 6.9

Driver source code is also available by request for porting to other versions or operating systems.

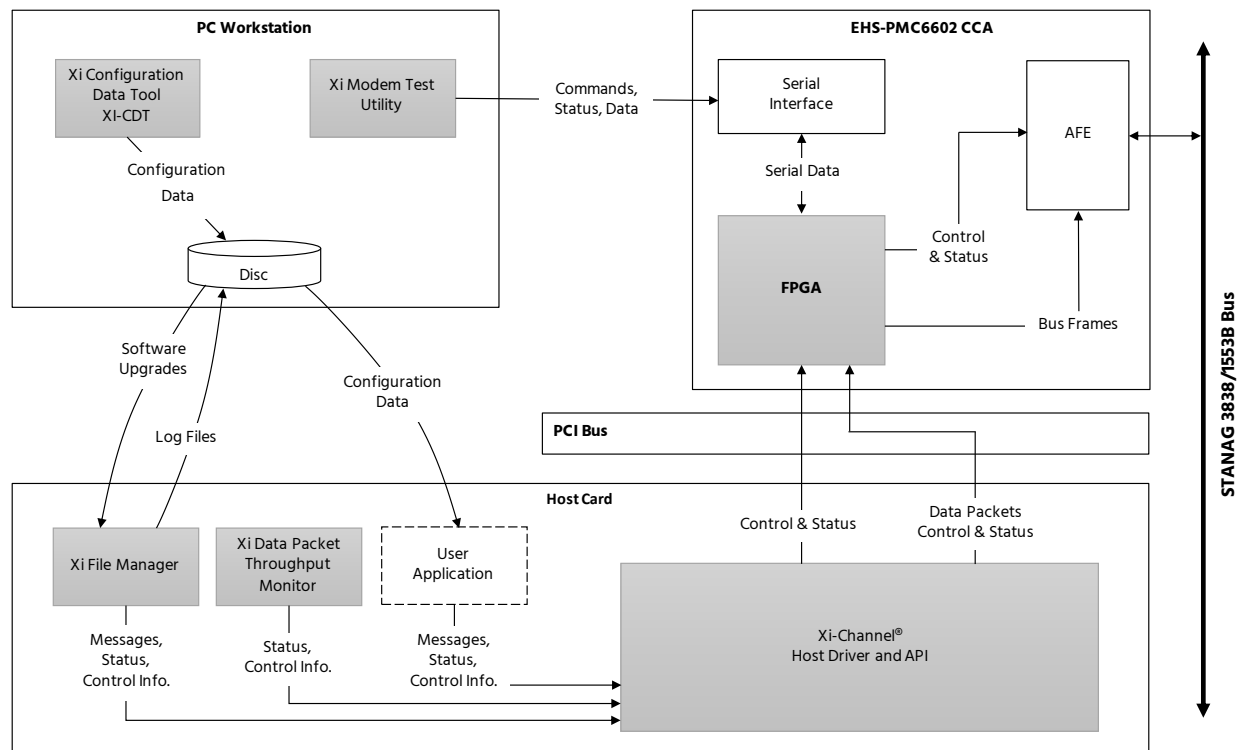

Figure 4: Software Component Structure

Software Tools

File Manager Software

The Xi File Manager is an application running on the host that uses the Host API to retrieve statistics and message logs gathered during flight and to upload software upgrades.

It can also access software upgrade images, stored on a network connected PC Development system, for subsequent loading onto the EHS-PMC6602 terminal.

Configuration Data Tool

The Xi Configuration Data Tool (XiCDT) is used to create the terminal, network, and schedule configuration data in either binary or ASCII format. User applications transfer this data to the terminal through Host API calls.

Data Throughput Monitor Software

The Xi Data Throughput Monitor is an application running on the host that employs the Host API to retrieve and display performance related statistics such as packet and error counts.

Xi Modem Test Utility

The Xi Modem test utility provides direct access to the EHS-PMC6602 terminal configurations settings to monitor and change the parameters and to view certain aspects of system operation.

This tool runs on a PC type workstation and is intended to support lab testing and network characterization. To allow for flexible system deployment configuration, two connection methods are defined: an Ethernet based connection and a serial port connection.

External Interfaces

The external hardware interfaces provide the physical link between the EHS-PMC6602 terminal, the Host computer, and the 3838/1553B network. Edgewater document 9001074 EHS-PMC5602 Hardware Reference Manual contains a full definition of the external interfaces.

Power

Primary power to the EHS-PMC6602 terminal is provided through the PMC PCI connectors P11 and P12.

The maximum ambient temperature power dissipation is 6.5W. The maximum current draw per power rail is as follows:

Table 1: EHS-PMC6602 Terminal Power Consumption

Power Supply (V)	Max Current (A)	Max. Input Noise (to 20MHz) mV pk-pk
+3.3 ± 5%	1.005	50
+5 ± 5%	0.497	50
+12 ± 5%	0.052	240

Low Power Mode/High Temperature Cut-off

Two discrete inputs, which enable host control of the EHS-PMC6602 terminal Low Power Mode, are provided through PMC I/O connector P14. Using the control signals the host can:

- Force the terminal into Low Power Mode (LOW_PWR# = Low)
- Override the terminal high temperature shutdown switch (LP_OVR = High)

- Permit normal operation of high temperature shutdown circuit function (LOW_PWR# = High, LP_OVR = Low)

PCI Bus

The EHS-PMC6602 Host interface is provided through the PMC PCI connectors P11 and P12 and is a PCI Local Bus as defined by PCI V2.3 with a bus clock rate of up to 33MHz. The EHS-PMC6602 terminal does not currently support 66 MHz PCI. The EHS-PMC6602 terminal supports 3.3V bus signaling only.

The EHS-PMC6602 terminal implements the PRESENT signal defined in ANSI/VITA-32-2003.

P14 User IO

JTAG Interface – Maintenance use only

3838/1553B Bus

The 3838/1553B bus interface is provided through the PMC I/O connector P14. By selecting the appropriate pin connections on P14, a STANAG 7221 compliant network interface is available in either transformer coupled or direct coupled mode. Component changes are not required to switch between transformer and direct coupled options.

A pass-through feature allows an external legacy 3838/1553B network to be combined with the STANAG 7221 network via a set of dedicated pins on P14. The legacy 3838/1553B data is passed through a passive low pass filter but is not otherwise processed or intercepted by the EHS-PMC6602 terminal. Network connections are provided to both A and B buses. When a legacy 3838 terminal is connected through the pass-

EHS-PMC6602 Data Sheet

STANAG 7221 Network Interface Card RT

September 2017

through interface there is the equivalent of two RTs connected to the 3838 bus.

Serial I/O

Serial I/O channels are provided through the PMC I/O connector P14 for test and monitoring activities associated with the EHS-PMC6602 terminal. The channels use data transmit and receive signals only. Hardware flow control is not used.

The interface is 3.0V LVCMOS. The TX and RX signals must be converted to RS-232 levels external to the terminal.

This interface is not used during normal operation of the EHS-PMC6602 terminal.

STANAG 7221 RT Address

Six RT address bits, one parity select bit, one mode select (7221 BC/RT) bit, an Address Lock bit, and a Mode Lock bit are provided through the PMC I/O connector P14 as Ground/Open type discrete inputs. The interface is odd parity protected.

The state can be read by external applications under Host control and the RT address and mode can be changed by the host if not locked on the external interface.

GPIO

Two single ended, 3 Volt Low Voltage Transistor-Transistor Logic (LVTTTL) compatible, discrete General Purpose I/Os (GPIO) are provided through the I/O connector P14. Each GPIO is pulled up to +3V by a 4.75K Ω resistor.

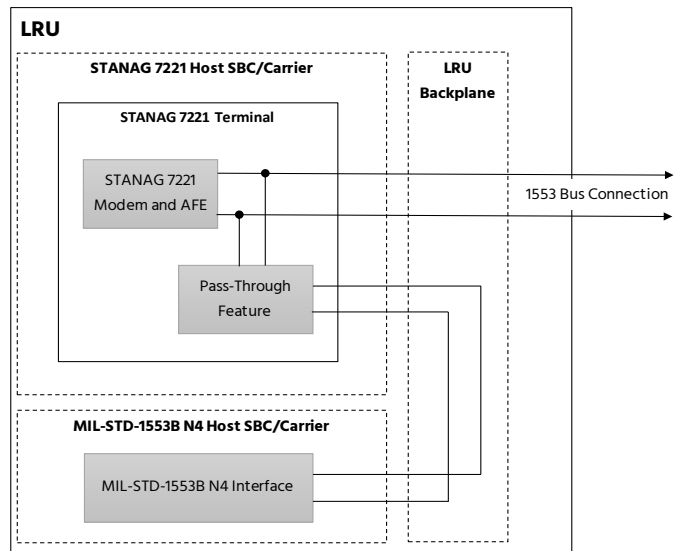

Figure 5: Legacy hookup through a Pass-Through Feature

EHS-PMC6602 Data Sheet

STANAG 7221 Network Interface Card RT

September 2017



EHS-PMC6602 PMC Pin Assignments

Table 2: P11 Pin Assignments

P11							
Pin #	Signal Name	Signal Name	Pin #	Pin #	Signal Name	Signal Name	Pin #
1	TCK	-12V	2	33	FRAME# (1)	GROUND	34
3	GROUND	INTA#	4	35	GROUND	IRDY#	36
5	INTB#(1)	INTC# (1)	6	37	DEVSEL#	+5V	38
7	PRESENT# (2)	+5V	8	39	GROUND	LOCK# (1)	40
9	INTD# (1)	PCI_RSVD (3)	10	41	PCI_RSVD (3)	PCI_RSVD	42
11	GROUND	+3.3Vaux (1)	12	43	PAR	GROUND	44
13	CLK	GROUND	14	45	V(I/O)	AD[15]	46
15	GROUND	GNT#	16	47	AD[12]	AD[11]	48
17	REQ#	+5V	18	49	AD[09]	+5V	50
19	V(I/O)	AD[31]	20	51	GROUND	C/BE[0]#	52
21	AD[28]	AD[27]	22	53	AD[06]	AD[05]	54
23	AD[25]	GROUND	24	55	AD[04]	GROUND	56
25	GROUND	C/BE[3]#	26	57	V(I/O)	AD[03]	58
27	AD[22]	AD[21]	28	59	AD[02]	AD[01]	60
29	AD[19]	+5V	30	61	AD[00]	+5V	62
31	V(I/O)	AD[17]	32	63	GROUND	REQ64# (1)	64

NOTES:

- (1) PCI signals not used by the terminal.
- (2) PRESENT# replaces BUSMODE[1]#.
- (3) Reserved for implementation of future PCI signals.

EHS-PMC6602 Data Sheet

STANAG 7221 Network Interface Card RT

September 2017



Table 3: P12 Pin Assignments

P12							
Pin #	Signal Name	Signal Name	Pin #	Pin #	Signal Name	Signal Name	Pin #
1	+12V	TRST# (1)	2	33	GROUND	PMC_RSVD (4)	34
3	TMS (1)	TDO (2)	4	35	TRDY#	+3.3V	36
5	TDI (2)	GROUND	6	37	GROUND	STOP#	38
7	GROUND	PCI_RSVD (3)	8	39	PERR#	GROUND	40
9	PCI_RSVD (3)	PCI_RSVD (3)	10	41	+3.3V	SERR#	42
11	BUSMODE[2]#(1)	+3.3V	12	43	C/BE[1]#	GROUND	44
13	RST#	BUSMODE[3]# (1)	14	45	AD[14]	AD[13]	46
15	+3.3V	BUSMODE[4]# (1)	16	47	M66EN	AD[10]	48
17	PME#	GROUND	18	49	AD[08]	+3.3V	50
19	AD[30]	AD[29]	20	51	AD[07]	PMC_RSVD (4)	52
21	GROUND	AD[26]	22	53	+3.3V	PMC_RSVD (4)	54
23	AD[24]	+3.3V	24	55	PMC_RSVD (4)	GROUND	56
25	IDSEL	AD[23]	26	57	PMC_RSVD (4)	PMC_RSVD (4)	58
27	+3.3V	AD[20]	28	59	GROUND	PMC_RSVD (4)	60
29	AD[18]	GROUND	30	61	ACK64# (1)	+3.3V	62
31	AD[16]	C/BE[2]#	32	63	GROUND	PMC_RSVD (4)	64

NOTES:

- (1) PCI signals not used by the terminal.
- (2) TDI is connected to TDO.
- (3) Reserved for implementation of future PCI signals.
- (4) Reserved for implementation of future PMC signals.

EHS-PMC6602 Data Sheet

STANAG 7221 Network Interface Card RT

September 2017



Table 4: P14 Pin Assignments (User IO)

P14							
Pin #	Signal Name	Signal Name	Pin #	Pin #	Signal Name	Signal Name	Pin #
1	NIC_RSVD (1)	NIC_RSVD (1)	2	33	NIC_RSVD (1)	NIC_RSVD (1)	34
3	RT_AD_RTN	RT_AD_PAR	4	35	NIC_RSVD (1)	GROUND	36
5	RT_AD[5]	RT_AD[0]	6	37	NIC_RSVD (1)	RX	38
7	RT_AD[1]	RT_AD[2]	8	39	TX	GPIO[0]	40
9	RT_AD[3]	RT_AD[4]	10	41	GPIO[1]	NIC_RSVD (1)	42
11	AFE_GROUND	MUX_AH_TC	12	43	NIC_RSVD (1)	NIC_RSVD (1)	44
13	MUX_AL_TC	AFE_GROUND	14	45	MSEL_LOCK	+3.0V (out)	46
15	MUX_BL_TC	MUX_AH_DC	16	47	NIC_RSVD (1)	NIC_RSVD (1)	48
17	MUX_BH_TC	MUX_AL_DC	18	49	LOW_PWR#	LP_OVR	50
19	AD_LOCK#	MSEL	20	51	5.0V (out)	+3.3V (out)	52
21	AFE_GROUND	AFE_GROUND	22	53	5.0V (out)	+3.3V (out)	54
23	AFE_GROUND	MUX_BH_DC	24	55	NIC_RSVD (2)	NIC_RSVD (2)	56
25	AFE_GROUND	MUX_BL_DC	26	57	NIC_RSVD (2)	GROUND	58
27	AFE_GROUND	MUX_AH_PT	28	59	NIC_RSVD (2)	GROUND	60
29	MUX_BH_PT	MUX_AL_PT	30	61	NIC_RSVD (2)	NIC_RSVD (2)	62
31	MUX_BL_PT	NIC_RSVD (1)	32	63	NIC_RSVD (2)	NIC_RSVD (2)	64

NOTES:

- (1) Reserved for terminal product development and support. Do not connect.
- (2) Reserved for future terminal use. Do not connect.

All pins:

- All terminal-specific signals may be isolated from the P14 plug by removing specific zero ohm resistors on the terminal. Contact Edgewater for further information.
- Upon customer request, P14 pin assignments may be reconfigured by use of soldered wire jumpers. Contact Edgewater for further information.

Specifications

Card Type

PCI Mezzanine Card (PMC)

Host Interface

PCI

Temperature

Storage: -55°C to 95°C

Operation: -40°C to 85°C

Power Dissipation Typ/Max¹

6.0W/6.5W

Relative Humidity

1% to 95% non-condensing

Altitude

-15,000ft. to 70,000ft.

(-700m to 21,350m)

Shock

1. MIL-STD-810G, method 516.6; Procedure VI (Bench Handling)
2. MIL-STD-810G, Method 516.6, procedure I, Test Category as defined by paragraph 2.3.2c, Figure 516.6-10 (Functional)
3. RCTA/DO-160D Section 7 (Operational)

Vibration

MIL-STD-810G method 514.6 Procedure I

Acceleration

MIL-STD-810G, Method 513.6, Procedure I & II

STANAG 7221

- STANAG 7221 compliant
- Remote Terminal
- Transformer/Direct Coupled

Ordering Information

Part Numbers

EHS-PMC6602-L (non-conformally coated)

EHS-PMC6602-M (conformally coated)

Available

Now

Contact: sales@edgewater.ca

Phone: + 1 613 271 1101 x 3074

Website: www.edgewater.ca

¹ Measured at 25°C